

NATIONAL TECHNICAL UNIVERSITY OF UKRAINE
«IGOR SIKORSKY KYIV POLYTECHNIC INSTITUTE»
FACULTY OF BIOMEDICAL ENGINEERING

Approved by

Head of the Attestation Commission of
the Faculty of Biomedical Engineering

Dean Vitalyi MAKSYMENKO

«25» April 2022 year

STAMP

PROGRAM OF
Comprehensive attestation exam
for educational professional program
bachelor “Medical engineering”
specialization 163 Biomedical engineering

Program approved by

Department of biomedical engineering

Protocol № 11 from « 15 » « April » 2022 year

Head of the department Vladislav SHLYKOV

Kyiv – 2022

INTRODUCTION

The comprehensive attestation exam covering the educational professional bachelor's program “Medical engineering” is carried out for students who have successfully completed the individual curriculum during the first (bachelor's) level of higher education in the educational program 163 “Biomedical engineering”.

The comprehensive attestation exam aims to assess the level of knowledge of students in the disciplines that are most important for the formation of professional competencies. The comprehensive attestation exam is a written exam including the following disciplines: Mechanics (PO 10), Object-oriented Programming (PO 11), Analog and digital circuitry - 2. Digital circuitry (PO 13). The examination lasts for 2 academic hours (90 minutes) - without a break. The examination task contains three questions – one for each discipline.

MAIN EXPLANATION

Content of educational material required for examination

Discipline 1. **Object-oriented programming**

- 1.1. Differences between procedural, object and object-oriented programming.
- 1.2. Object-oriented programming, design and analysis. Basic concepts and definitions.
- 1.3. Basic concepts and definitions of object-oriented programming: the concept of class and object, the relationship between class and its objects in the program.
- 1.4. Object-oriented programming style paradigm: inheritance, polymorphism, encapsulation. Definitions and explanations with examples.
- 1.5. What is a preprocessor? What is a compiler? What are preprocessor directives? What is their purpose?
- 1.6. Features of syntax for realization of linear structures. Branching, selection and cycles.
- 1.7. How to declare an array? Describe the basic operations of array processing.

1.8. Describe the purpose of the functions and the features of their declaration. Features of returning and using the value of functions.

1.9. What is recursion? Give examples of recursive algorithms.

1.10. Definition and declaration of global objects and functions.

1.11. C ++ class description format, example code with explanation. Purpose and differences between the forms class, struct, union.

1.12. Class fields, their purpose. The difference between class fields and variables in the program code, the principles of defining and initializing fields.

1.13. Class methods, their purpose.

1.14. Defining and working with class objects, examples. The lifetime of objects.

1.15. Format of definition and rules for objects and array of objects use. Code examples to explain the rules for initializing static and dynamic object arrays.

1.16. The concept of encapsulation. Class member access status, public, private, protected access specifiers.

1.17. The concept of encapsulation. Methods for setting and obtaining class field data, features of their definition in the program code. Give examples of program code using set/get methods with explanations.

1.18. Class member access operations. Determine the mechanism of transition to the use of point operations when working with pointers. Pointer this and its use (the most common situations, relevant examples).

1.19. Class constructor and its purpose. Format and rules for using default constructors and parameter constructors. Initialization list.

1.20. Class destructor and its purpose. Cases of implicit calls for destructors.

1.21. Purpose and rules of using constant class methods. Constant objects, the specifics of using the mutable specifier.

1.22. Static class members, access to static class members. Memory allocation when working with classes, specifics of memory allocation for fields and for class methods, static fields and methods.

1.23. Format of declaration, purpose and rules of how to use friendly functions and classes. Relevant examples of program code with explanations.

1.24. The concept of inheritance, general form. Hierarchy of classes, base class and descendant classes. Constructors and destructors in inheritance.

1.25. Overloading operations, two ways to identify overloaded operators.

1.26. Operations that cannot be overloaded are the reasons. Operations that cannot be overloaded with global friendly functions, reasons.

1.27. The principle of polymorphism. The main forms of the polymorphism principle in the C ++ programming language, relevant examples of program code with explanations.

1.28. The concept of exceptional situation and its processing. Ways to handle errors in software applications. The syntax for generating and handling exceptions in the C ++ programming language.

1.29. Exceptional handling mechanism in C ++ programming language. Classes of exceptions. Pass the exception to the catch block by value and by link.

1.30. Standard types of exceptions from the std library. Assigned functions terminate (), unexpected (), abort () during exception handling. Give an example of a code that can be used to display a text message with the line number during which an exception occurred and the name of the file that contains that line.

1.31. Classes of standard flows, their hierarchy and purpose. Features of overloading read/write operations to the stream.

Discipline 2. Analog and digital circuitry - 2. Digital circuitry

2.1. Algebraic logic. Standard forms of logical functions. Minimization of logical functions.

2.2. Diode switches. Logic circuits on diodes. Switches on bipolar transistors.

2.3. Switches on Schottky transistor. Switches on unipolar transistors.

2.4. Diode-transistor (DTL) logic elements (LE). Basic LE AND-NO. DTL-elements OR-NO, AND-OR-NO. DTL element. Typical parameters of DTL.

2.5. Transistor-transistor LE (TTL). Basic LE AND-NO. TTL-elements OR-NO, AND-OR-NO. LE with a free collector. LE with three states of output. Typical parameters of TTL and TTLS.

2.6. LE on MISFET and CMOS transistors. LE AND-NO, OR-NO. Implementation of CDNF and CCNF on CMOS transistors. Buffer amplifiers. Protection of CMOS LE from static electricity. Conjugation of CMOS elements with TTL. Typical parameters of CMOS elements.

2.7. PC synthesis. Examples of PC implementation based on LE.

2.8. Encoders and decoders. Unitary code. Priority encoders. Decoders - linear, pyramidal, matrix. Minimize incomplete decoders. Synthesis of PC based on the decoder-encoder system.

2.9. Multiplexers and demultiplexers. Synthesis of multiplexers and demultiplexers. Gating, use of decoders in gating. Analog multiplexer-demultiplexer.

2.10. Combination shift devices on multiplexers. Implementation of logic functions on multiplexers.

2.11. Half-adders. Full adders. Subtractors. Subtractor adders. Binary-decimal adder.

2.12. Multi-bit adders with serial transfer. Multi-bit adders with accelerated transfer. Combination multipliers.

2.13. Digital comparators - single-bit and multi-bit. Binary minus comparators. Sectioned multi-bit comparators.

2.14. RS-triggers asynchronous and transparent synchronous. Varieties of RS-triggers (R-, S-, E-triggers). RS-triggers such as "latch" and MS.

2.15. D-flip-flops asynchronous and transparent synchronous. D-flip-flops and MS. D-flip-flops in counter mode.

2.16. Universal JK-triggers such as "latches" and MS. Basic parameters of triggers.

2.17. Parallel registers. Shear registers. Reversible shift registers. Ring registers. Register - "Johnson's counter".

2.18. Asynchronous and synchronous counters. Reversible counters. Frequency dividers.

2.19. Binary-decimal counters. Counters with a controlled conversion factor.

2.20. Synthesis of counters with an arbitrary table of transitions. Polynomial counters.

2.21. Pulse front detectors. Pulse expanders. Binding pulses to a constant level. Trigger pulse generators.

2.22. Timers. Self-oscillating pulse generators on logic elements.

2.23. Single vibrators and self-oscillating pulse generators on operational amplifiers. Shapers and generators of linear alternating current and voltage.

2.24. Digital-to-analog converter based on analog adder, resistive structure R-2R and current switches.

2.25. Analog-to-digital balancing converter. Parallel analog-to-digital converts.

Discipline 3. **Mechanics**

3.1. Determine the volume of the cylindrical sample of elastic biological material given a longitudinal deformation of 5%, the initial volume of the sample 105 mm^3 and the Poisson's ratio taken as 0.

3.2. A cylindrical sample of cortical bone with a cross-sectional area of 1 cm^2 is subjected to axial compression at 2 kN force. Determine the volumetric deformation of the sample under the following conditions: Poisson's ratio $\mu = 0.3$, Young's modulus $E = 8 \text{ GPa}$.

3.3. A cylindrical sample of cortical bone with a length of 4 cm and a cross-sectional area of 1 cm^2 is subjected to axial tension at 2 kN force. Determine the energy of elastic deformation under the following conditions: Young's modulus $E = 8 \text{ GPa}$.

3.4. Find the normal σ_θ and tangential τ_θ stress on a plane inclined at an angle $\theta = 60^\circ$ to the cross section of a rectangular bone specimen that is subjected to uniaxial tension at $\sigma = 7 \text{ MPa}$.

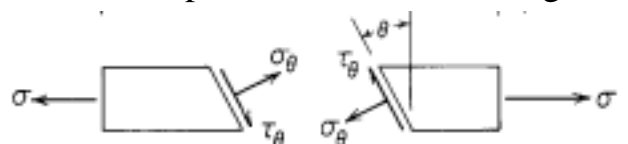

3.5. The distributed load on a 1 m section of a biological object is described by the equation: $w(x) = (x^{1/2})$, kN/m . Determine the equivalent of the distributed load and its distance from point 0.

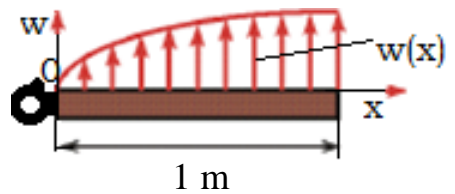

3.6. A prismatic rod with a cross-sectional area of 800 mm^2 is subjected to uniaxial tension at 60 kN force. Determine the normal and tangential stresses on the inclined area of the rod, the normal to which forms an angle $\theta = 30^\circ$ with the axis of the rod.

3.7. The distributed load acting on the rod of length L varies according to the equation: $w = (Ax^2)$ N/m , where A is a constant. Determine the equivalent force of the distributed load, the moment of force relative to the point O and the distance of the equivalent force from the origin.

3.8. Points A, B, C of a biological object with coordinates A (6, 0, 2); B (-3, 0, -2); C (-2, 0, 4) are exposed to a system of parallel forces:

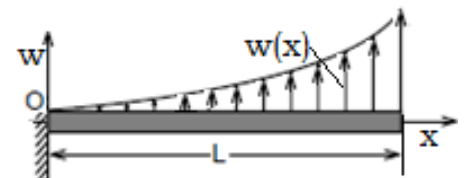

$\vec{F}_A = 30j$; $\vec{F}_B = 20j$; $\vec{F}_C = -10j$. Replace the specified system of forces with one equivalent force and determine the coordinates of the point of its application.

3.9. Determine the force of the reaction from the tibia F and the force T that is exerted on the Achilles tendon during squats on both legs under the following conditions: body weight 800 N; the angle between the force T and the horizontal $\alpha = 30^\circ$; $a = 60 \text{ mm}$, $b = 45 \text{ mm}$.

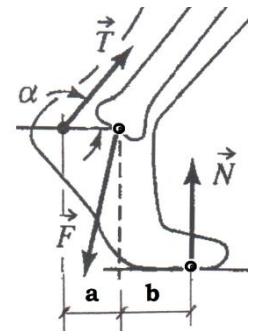

3.10. Determine the force R acting on the talus of the foot and the force F that is exerted on the Achilles tendon when standing on the tips of the toes of one foot under the following condition: body weight 500 N; the forces F and R applied at points A and B form angles with the horizon $\theta = 45^\circ$, $\beta = 60^\circ$, respectively; forces F, R, W are convergent.

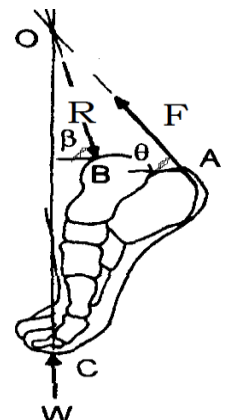

3.11. Determine the forces H_w, H_G, V_G exerted on the person from the side of the wall and floor. The person's weight 800 N, $AD = 160$ cm, $AG = 20$ cm, $AC = 80$ cm, $BD = 30$ cm. The AD line forms an angle with the horizon $\theta = 60^\circ$.

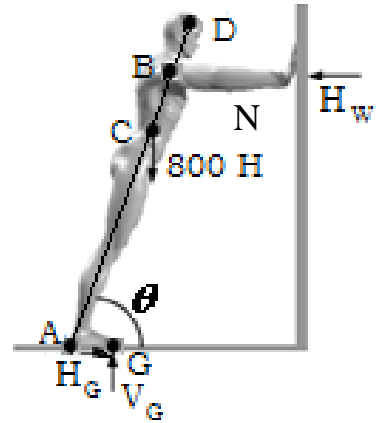

3.12. The following mechanical model is used to interpret the behavior of biological material under the action of tensile deformation:

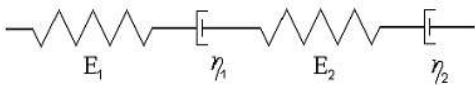

Derive a rheological equation that expresses the relationship between tensile stress σ , strain ε , and their derivatives in time.

3.13. The following mechanical model is used to interpret the behavior of biological material under the action of tensile deformation. Derive a rheological equation that expresses the relationship between tensile stress σ , strain ε , and/or their derivatives over time.

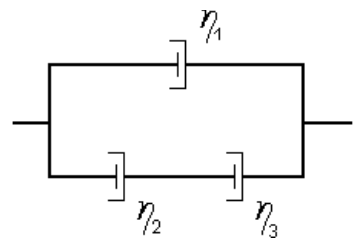

3.14. Calculate the yield strength and plastic viscosity of viscoplastic biological material, if the following data are obtained during its deformation: the shear stress $\tau_1 = 0,3$ Pa at the shear rate $\dot{\gamma}_1 = 0,1$ s⁻¹, while the shear stress $\tau_2 = 0,45$ Pa at the shear rate $\dot{\gamma}_2 = 0,25$ s⁻¹.

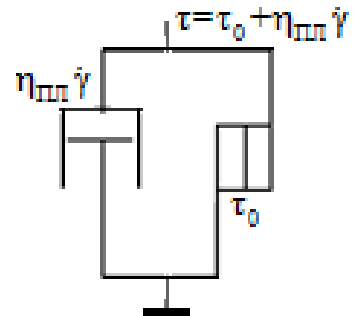

3.15. Determine the viscosity of the biological material, the rheological behavior of which corresponds to the Maxwell model, if 40 seconds after the applied stress of 24 Pa is maintained constant, the deformation increases from 0 to 6%.

3.16. Calculate the maximum rate of muscle contraction using the Hill equation $(P + a)(v + b) = (P_0 + a)b = a(v_{MAX} + b)$, provided that: the load in the isometric mode is $P_0 = 1.1$ N; a constant for the muscle = 0.2 N; muscle contraction rate at load $P = 0.3$ N is 24 mm/s.

3.17. Determine the radius-vector of the center of mass of the body if it is represented as two identical straight rods ab and bc with uniformly distributed masses hinged at point b at an angle of 135° . The length of each rod is L . Assume that the origin is at point b , the direction of the rod bc coincides with the x -axis.

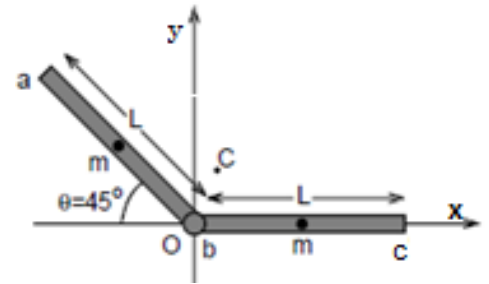

3.18. L rests on four point supports located at the tops of the plate. Under the action of the applied force R in the supports there are reaction forces $F_1 \neq F_2 \neq F_3 \neq F_4$. Determine the coordinates of the point of application of force at which the plate will remain in equilibrium. Neglect the weight of the plate.

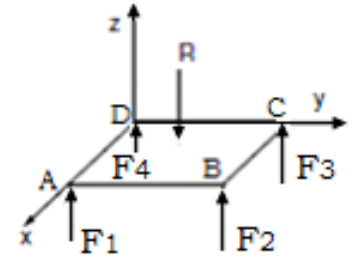

3.19. Calculate the moment of inertia of the lower limb of the sprinter relative to the axis passing through the center of the hip joint (HJ), if the moments of inertia of the thigh, leg and foot relative to their own centers of mass, respectively, are equal to: 0.105 ; 0.504 and 0.0038 kg m^2 . The distances of the centers of mass of the thigh, shin and foot from the axis of the vehicle are, respectively, 0.30 ; 0.45 and 0.53 m , and their masses – respectively equal to 7.21 ; 3.01 and 1.05 kg .

3.20. Determine the average linear velocity of blood in the daughter branches of the bifurcation prosthesis, if the average velocity in the main branch is 30 cm/s , and the diameter of the daughter branches is 60% of the diameter of the main.



3.21. The arm is displaced horizontally and holds the load. Determine the reaction force of the shoulder joint R and the force F that the deltoid muscle exerts under the following conditions: $OA = a$, $OB = b$, $OC = c$. The forces R and F form angles with the horizon β and θ , respectively.

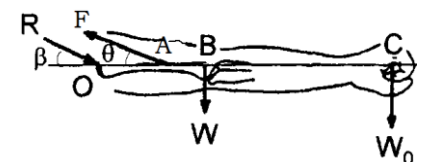

3.22. A spindle-shaped aneurysm with a diameter of 3 cm appeared on the horizontal section of the abdominal aorta with a diameter of 1.5 cm . The average normal blood flow velocity is 0.2 m/s . Determine the static pressure drop that occurs due to the

appearance of an aneurysm. Blood should be considered as an ideal fluid with a density of 1000 kg/m^3 , blood flow should be considered stable.

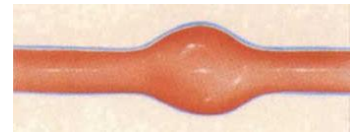

3.23. On the horizontal section of the carotid artery with a diameter of 1 cm there was a narrowing with a diameter of 0.5 cm. Determine the difference in static pressure that occurs due to narrowing. The average velocity of blood flow in the narrowed area is 0.3 m/s. Blood should be considered as an ideal fluid with a density of 1000 kg/m^3 , blood flow should be considered stable.

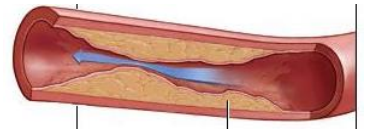

3.24. The patient is undergoing a blood transfusion procedure. Blood comes from the container through a tube into a needle introduced into a vein, the pressure of which is $9 \cdot 10^3 \text{ Pa}$. Determine the height h at which to install the container, under the following conditions: needle length 20 mm; inner diameter of 0.5 mm; volumetric blood flow $0.05 \text{ cm}^3/\text{s}$; blood density 1050 kg/m^3 ; blood viscosity coefficient $4 \cdot 10^{-3} \text{ Pa}\cdot\text{s}$.

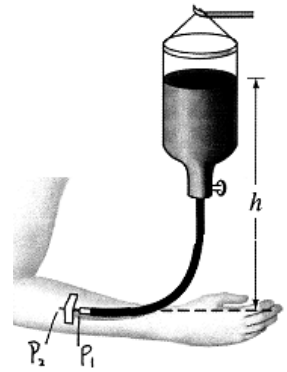

3.25. Determine the type of blood flow in a vessel with a diameter of 5 mm, at which in the parietal layer of the vessel there is an internal friction stress $\tau_w = 0.84 \text{ N/m}^2$. Blood density $\rho = 1000 \text{ kg/m}^3$, blood viscosity $\mu = 3,5 \cdot 10^{-3} \text{ Pa}\cdot\text{s}$.

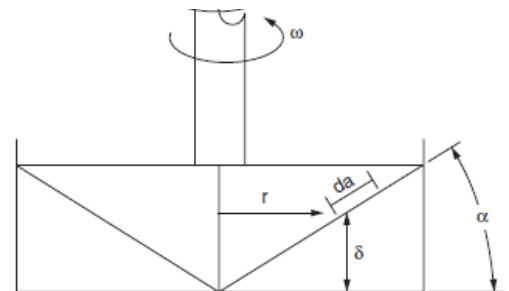

3.26. Determine to the type of a biological fluid, if the following parameters were measured using a rotary viscometer type cone-plane: at an angular velocity of 60, 30, 12 rad/min, the shear stress, respectively, was equal to: 1.8; 0.9; 0.36 Pa.

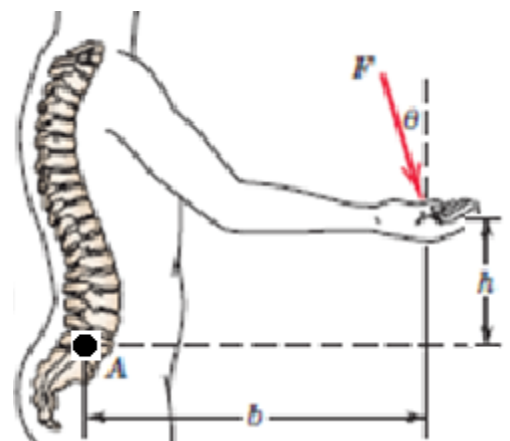

3.27. The lower lumbar spine (point A) is subjected to bending caused by the force F acting on the hand at an angle Θ . Determine the value of the angle Θ at which the maximum bending moment will occur at point A.

3.28. Determine the modulus of elasticity of the artery under the following conditions: outer diameter of the artery 9.4 mm, inner diameter 8 mm, blood density 1050 kg/m^3 , the speed of pulse wave propagation through the artery 10 m/s.

3.29. The sample of cortical bone tissue 15 mm long, 12 mm thick and 4 mm wide under the action of tensile force 480 N was elongated by $7,5 \cdot 10^{-4}$ mm. Determine the moduli of elasticity of I and II types for the bone tissue. Consider the Poisson's ratio equal $\mu = 0,25$.

3.30. Examination of the rheological properties of the blood sample collected the following data: at the shear rate $\dot{\gamma}_1 = 0,5 \text{ s}^{-1}$ the shear stress was $\tau_1 = 4,3 \text{ Pa}$, while at $\dot{\gamma}_2 = 0,1 \text{ s}^{-1}$ the shear stress was $\tau_2 = 5,2 \cdot 10^{-3} \text{ Pa}$. Determine the viscosity of blood, assuming that its rheological behavior is consistent with the Kesson model.

3.31. Determine the tension exerted on the urinary bladder wall under the following conditions: internal volume of the bladder 300 ml; wall thickness 4 mm; excess pressure in the bladder 1333 Pa. Consider the bladder as a sphere.

3.32. Determine the tension exerted on the wall of the left ventricle of the heart, at which the excess pressure in the ventricular cavity is 24 kPa. The ventricle is considered a spherical thin-walled shell with an average diameter of 6 cm and a wall thickness of 10 mm.

3.33. The study of the rheological properties of the blood sample collected the following data: at the shear rate of $\dot{\gamma}_1 = 0,05 \text{ s}^{-1}$ the shear stress was $\tau_1 = 4,3 \cdot 10^{-3} \text{ Pa}$, while at $\dot{\gamma}_2 = 0,1 \text{ s}^{-1}$ the shear stress was equal to $\tau_2 = 5,2 \cdot 10^{-3} \text{ Pa}$. Determine the limit of blood flow, assuming that its rheological behavior corresponds to the Kesson model.

CONCLUDING REMARKS

During the comprehensive attestation exam, a student receives the examination task comprising three questions of equal complexity (from each discipline). The final mark is defined as the sum of the points scored for the answers to each of the three questions of the examination task. Evaluation criteria are applied to task verification based on the completeness, logic and correctness of the disclosure of the question. The maximum weight score is 100 points: the maximum number of points for the first and second questions – 33 and for the third – 34.

Evaluation criteria for the first and second questions with points:

- complete answer with explanations (not less than 90% of the required information), does not contain off-topic information - 33... 31 points;
- complete answer with minor inaccuracies (not less than 80% of the required information), does not contain off-topic information - 30... 27 points;
- in principle correct answer with minor inaccuracies (not less than 70% of the required information), some information is off-topic - 26... 23 points;
- complete answer with inaccuracies (not less than 60% of the required information) – 22...20 points;
- incomplete answer with no major inaccuracies (at least 50% of the required information), including errors – 19...17 points;
- incomplete answer with major errors and (or) major inaccuracies (less than 50% of the required information) – 16... 1 points;
- no answer provided – 0 points.
- Evaluation criteria for the third question with points:
- complete answer with explanations (not less than 90% of the required information), does not contain off-topic information - 34... 32 points;
- complete answer with minor inaccuracies (not less than 80% of the required information), does not contain off-topic information - 31... 27 points;
- in principle correct answer with minor inaccuracies (not less than 70% of the required information), some information is off-topic - 26... 23 points;

- complete answer with inaccuracies (not less than 60% of the required information) – 22...20 points;
- incomplete answer with no major inaccuracies (at least 50% of the required information), including errors – 19...17 points;
- incomplete answer with major errors and (or) major inaccuracies (less than 50% of the required information) – 16... 1 points;
- no answer provided – 0 points.

During the exam, it is allowed to use a calculator, basic formulas and a table of digital codes. Supporting materials are provided by the examiner.

Additional points for achievements in research work during university studies (not exceeding 10 points or 10% of the maximum number of points):

- Research articles and patents in the field of specialty*:
 - research article indexed in Scopus & Web of Science – 5 points;
 - research article indexed in all other international scientometric databases – 4 points;
 - research article indexed in the periodical professional publications of Ukraine or in the list of scientific professional publications approved by the Ministry of Education and Science of Ukraine – 3 points;
 - other research articles – 2 points;
 - patent for invention – 5 points;
 - utility model patent – 3 points;
 - objects and rights of intellectual property – 3 points.

* In the case of co-authored work, the number of gained points is divided by the number of co-authors.

- Conferences in the field of specialty (only with published abstracts)*:
 - participation in All-Ukrainian or international conferences (in Ukraine) – 2 points;
 - participation in an international conference (abroad) – 3 points;
 - participation in faculty / institute / university conferences – 2 points;
 - report/poster at the conference without published abstracts – 1 point;
 - award for the best report at the All-Ukrainian or international conference – 1 point.

* In the case of co-authored work, the number of gained points is divided by the number of co-authors.

- Olympiads and competitions for innovative projects, research works in the field of specialty*:
 - award given at the International Olympiad – 5 points;
 - award given at the international scientific competition/project (startup projects, hackathon, etc.) – 5 points;
 - award given at the second round of the All-Ukrainian Olympiad (according to the list of the Ministry of Education and Science of Ukraine) – 3 points;
 - award given at the All-Ukrainian scientific competition / project (startup projects, hackathon, etc.) – 3 points;
 - award given at the All-Ukrainian competition of student's research works (according to the list of the Ministry of Education and Science of Ukraine) – 3 points;
 - award given at other olympiads/competitions – 1 point.

* In the case of teamwork, the number of gained points is divided by the number of team members.

A typical example of the comprehensive attestation exam task

NATIONAL TECHNICAL UNIVERSITY OF UKRAINE

«IGOR SIKORSKY KYIV POLYTECHNIC INSTITUTE»

Specialization	163 Biomedical engineering
Educational professional program	Medical engineering
Exam	Comprehensive attestation exam

EXAMINATION TASK № 1

1. Differences between procedural, object and object-oriented programming.
2. Binary-decimal counters. Counters with a controlled conversion factor.
3. Determine the volume of the cylindrical sample of elastic biological material given a longitudinal deformation of 5%, the initial volume of the sample 105 mm^3 and the Poisson's ratio taken as 0.

Materials and resources

Object-oriented programming

Basic literature

1. Васильєв О. Програмування на С++ в прикладах і задачах : навчальний посібник / Олексій Васильєв. - Київ : Видавництво Ліра-К, 2020. – 381 с.
2. Путятін Є.П. Основи програмування мовою С++ : навчальний посібник / Є.П. Путятін, В.А. Любченко, О.А. Кобилін, Д.О. Руденко, Д.С.Пелешенко. - Харків : С.Ф. Коряк, 2018. - 282 с.
3. Гришанович Т. О. Основи об'єктно-орієнтованого програмування : навч. Посіб. / Т.О.Гришанович; СНУ ім. Лесі Українки. - Харків : ФОП Панов А.М., 2020. - 104 с.
4. Матвієнко М. П. Теорія алгоритмів. Навчальний посібник. — К.: Видавництво Ліра-К, 2017. — 340 с.

Additional literature

5. Алгоритмізація та програмування мовою високого рівня С++ : комп'ютерний практикум: навчальний посібник для студентів, які навчаються за спеціальністю 122 "Комп'ютерні науки та інформаційні технології", спеціалізацією "Інформаційні технології в біології та медицині" / С.М. Алхімова; Міністерство освіти і науки України, Національний технічний університет України "Київський політехнічний інститут імені Ігоря Сікорського". - КПІ ім. Ігоря Сікорського, 2018. - 154 с.

6. Шилдт, Герберт, С++ : базовый курс / Герберт Шилдт ; перевод с английского Н.М. Ручко. - Київ : Діалектика, 2020. - 620 с.

7. Іванов Є.О., Ліндер Я.М., Жереб К.А. Основи мови програмування С++: навчальний посібник. – К.: Логос. 2020. – 90 с.

Digital circuitry

Basic literature

1. Цифрова схемотехніка. Конспект лекцій до вивчення кредитного модуля дисципліни «Цифрова схемотехніка» [Електронний ресурс] : навчальний посібник для студентів, які навчаються за спеціальністю 163 – Біомедична інженерія, спеціалізацією «Клінічна інженерія» / КПІ ім. Ігоря Сікорського ; уклад.: В. І. Зубчук, М. Делавар-Касмаї. – Електронні текстові данні (1 файл 2,61 Мбайт). – Київ : КПІ ім. Ігоря Сікорського», 2019. – 184 с.

2. Цифрова схемотехніка [Електронний ресурс] : практикум з дисципліни для студентів спеціальностей 6.051402 - «Біомедична інженерія» та 6.051003 «Приладобудування» / В. І. Зубчук, Н. В. Захарчук ; КПІ ім. Ігоря Сікорського. – Електронні текстові данні (1 файл: 5,07 Мбайт). – Київ : КПІ ім. Ігоря Сікорського, 2017. – 194 с.

3. Рябенський В.М. Цифрова схемотехніка : навчальний посібник для студентів вищих навчальних закладів / В.М. Рябенський, В.Я. Жуйков, В.Д. Гулий. - Львів : Новий Світ-2000, 2019. - 735 ст.

Additional literature

4. Борисенко О.А. Цифрова схемотехніка : підручник / О.А. Борисенко ; Міністерство освіти і науки України, Сумський державний університет. - Суми : Університетська книга, 2016. - 199 с.

5. Карташов В.М. Цифрова схемотехніка: підручник / В.М. Карташов, Л.П. Тимошенко ; за редакцією В.М. Карташова ; Міністерство освіти і науки України, Харківський національний університет радіоелектроніки. - Харків : С.Ф. Коряк, 2018. - 270 с.

Mechanics

Basic literature

1. Лебедь О.О., Гаращенко В.І., Григус І.М. Біологічна та медична механіка. Навч. посібник. – Рівне: НУВГП, 2016. – 186 с.

2. Тарасова, Л. Д. Біомедична механіка. Збірник завдань до домашніх контрольних робіт [Електронний ресурс] : навч. посіб. для здобувачів ступеня бакалавра за освітньою програмою «Медична інженерія» спеціальності 163 «Біомедична інженерія» / Л. Д. Тарасова ; КПІ ім. Ігоря Сікорського. – Електронні текстові дані (1 файл: 1,36 Мбайт). – Київ : КПІ ім. Ігоря Сікорського, 2020. – 45 с.

3. Конспект лекцій з дисципліни «Біомедична механіка» для здобувачів освітнього рівня «бакалавр» спеціальності 163 – Біомедична інженерія, освітня програма «Біомедична інженерія» / уклад. Д. Х. Штофель. Вінниця : ВНТУ, 2020. - 83 с.

Additional literature

4. Омаров М.А. Основи теоретичної механіки. Ч. 1: навч. посібник. – Харків: ХНУРЕ, 2017. – 184 с.
5. Драчук С. П., Богуславська В. Ю, Сокольвак О. Г. Біомеханіка людини. Тлумачний словник-довідник. Вінниця : ТОВ «Твори», 2019. - 400 с.
6. Біомедична механіка [Електронний ресурс] : методичні вказівки для лабораторних робіт з курсу «Біомедична механіка» для студентів спеціальності 163 «Біомедична інженерія» денної форми навчання / уклад. О. М. Сорочан. – Маріуполь : ПДТУ, 2020. – 41 с. – Режим доступу: <http://umm.pstu.edu/handle/123456789/21164>
7. Рибак О.Ю., Рибак Л.І. Вибрані лекції з біомеханіки : методичний посібник для студентів ЛДУФК ім. І. Боберського. Львів: Львівський державний університет фізичної культури імені Івана Боберського. – 2017. – 131 с.

PROGRAM DEVELOPERS

Vladislav SHLYKOV, D.Sci., Assoc Prof.

Viktor ZUBCHUK, Ph.D., Assoc Prof.

Larisa TARASOVA, Ph.D., Assoc Prof.
